

Zoom de Vista lateral

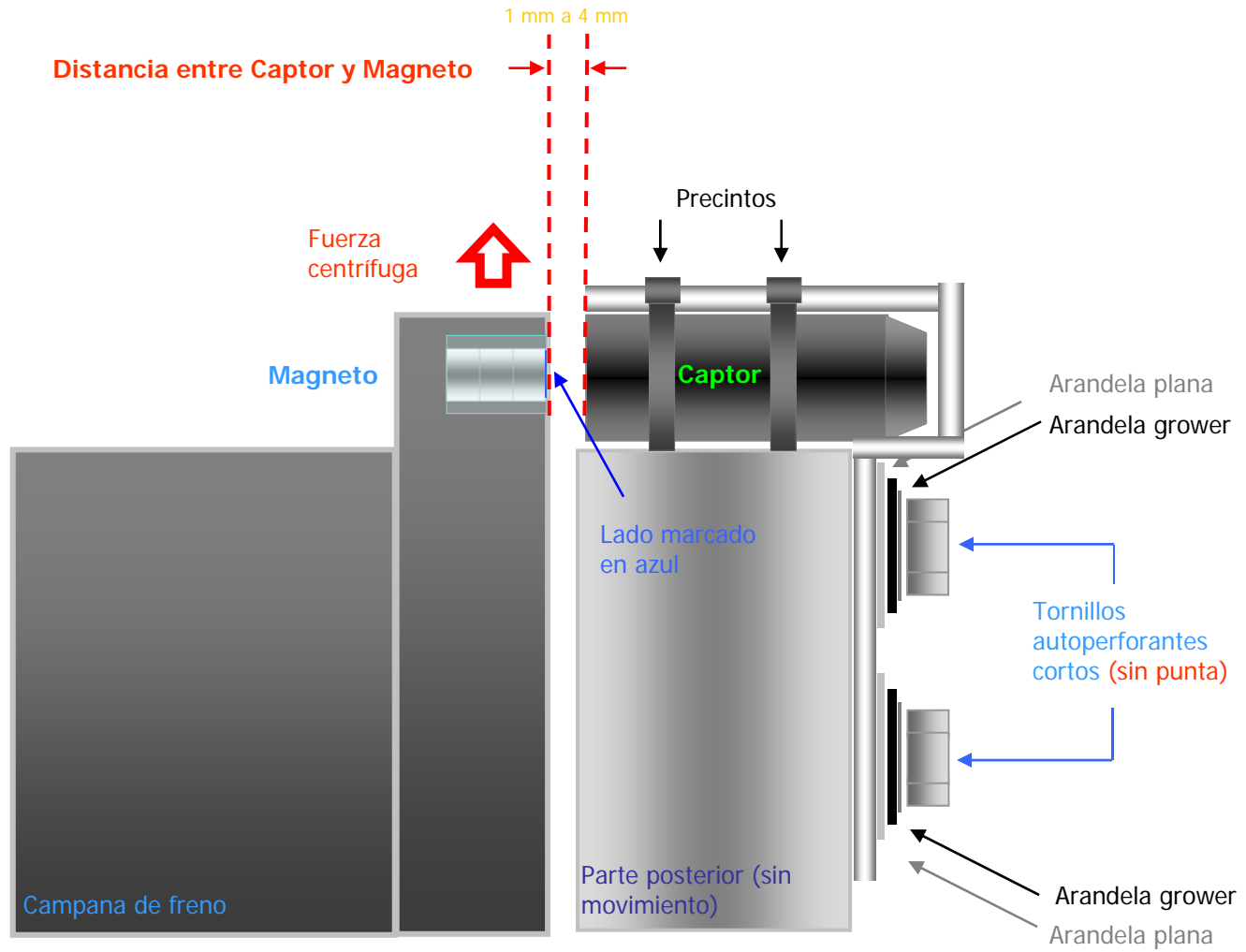

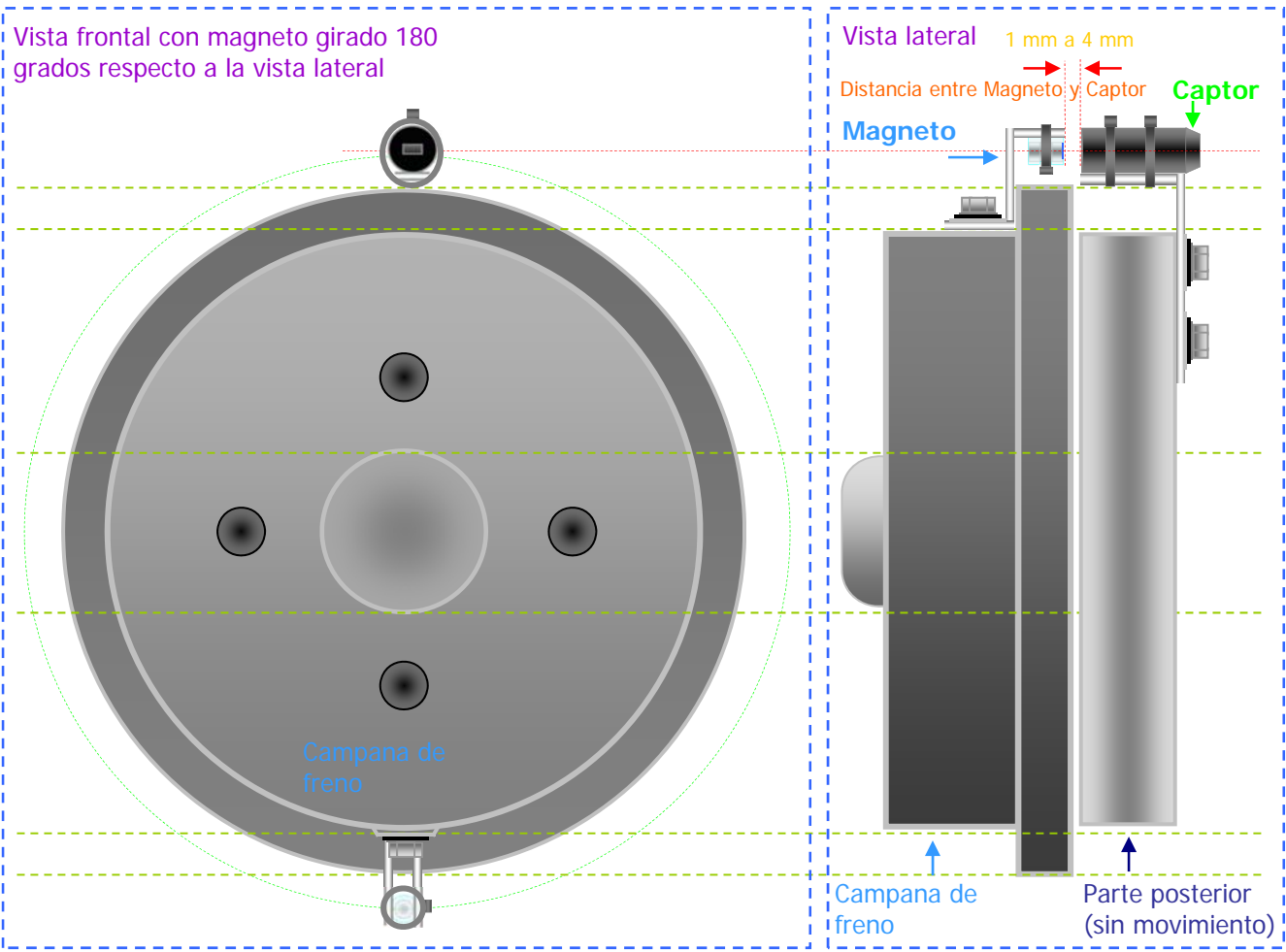

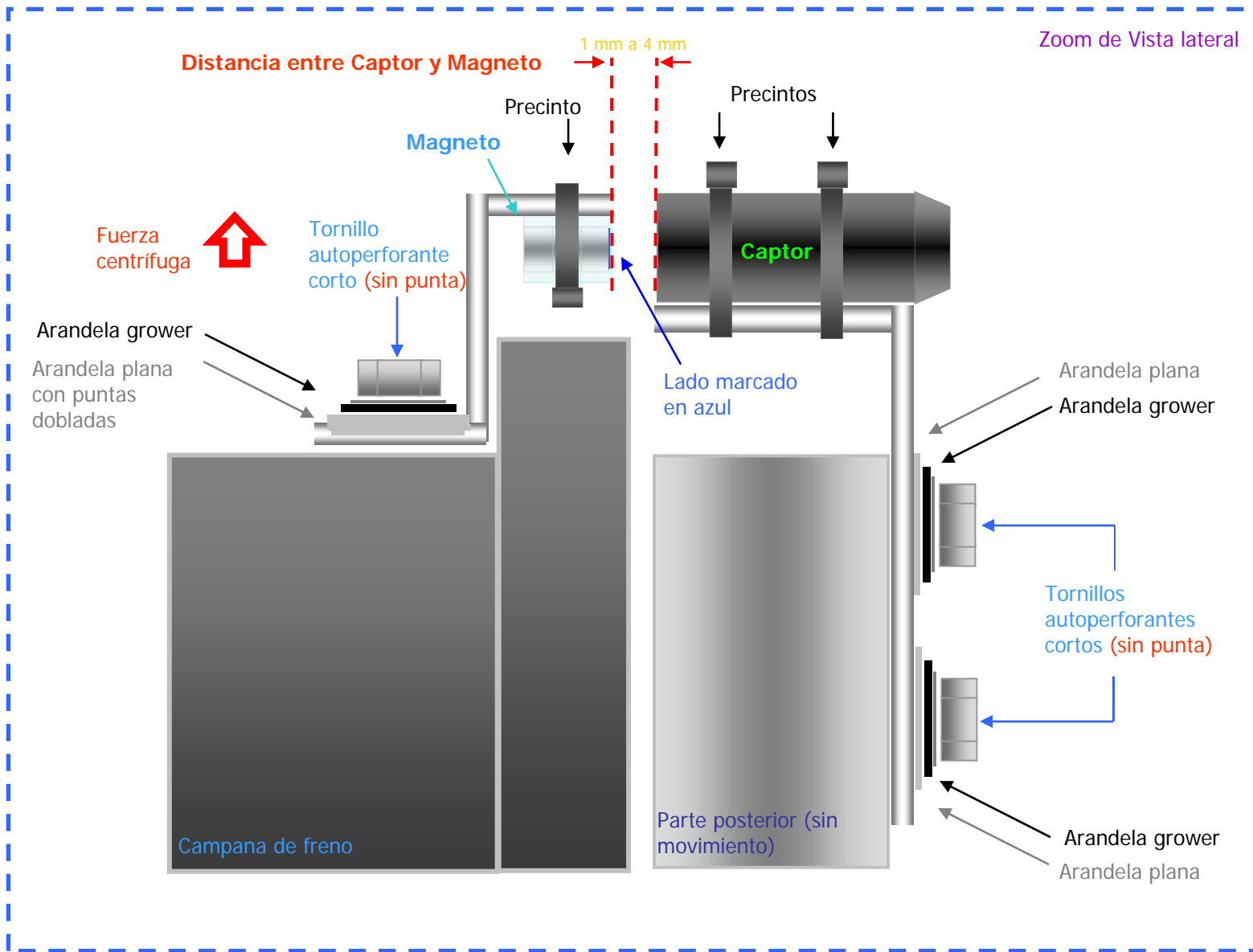

## Captor

Vista frontal

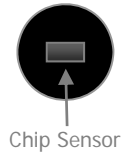

Vista lateral

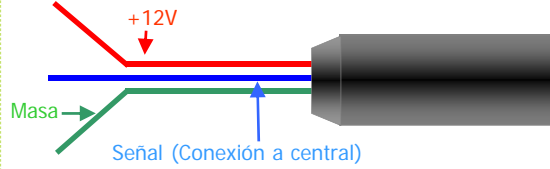

## Magneto

Vista frontal



Lado marcado en azul debe enfrenar al captor

Vista lateral



Ranura para precinto

Vista posterior



Protección plástica

## Soporte de Captor

Vista superior



Ranuras para precintos

Vista lateral

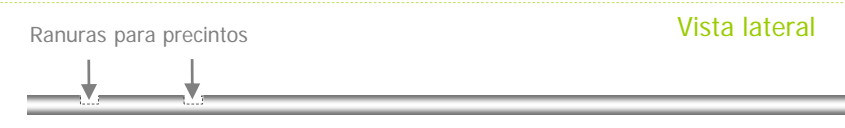

Ranuras para precintos

## Soporte de magneto

Vista frontal

Ranuras para precinto

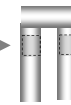

Vista superior



Vista lateral

Ranura para precinto



## Captor ensamblado en soporte

Vista superior

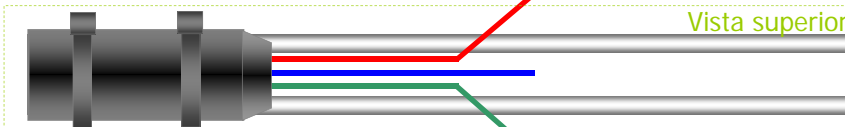

Vista lateral

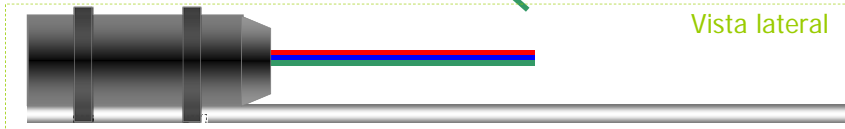

Ranuras para precintos en soporte

## Magneto ensamblado en soporte

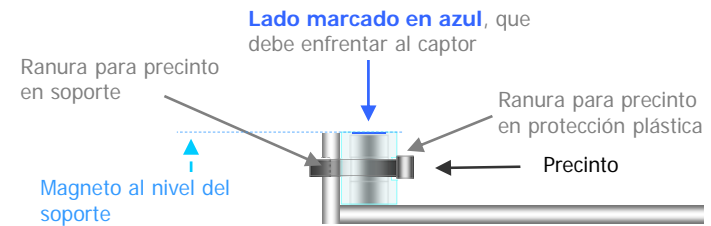

Ejemplo de cómo NO se debe instalar el magneto, ya que la fuerza centrífuga podría sacarlo

